

**DIGIT CUBE**

**#BUILDING\_INSTRUCTION**

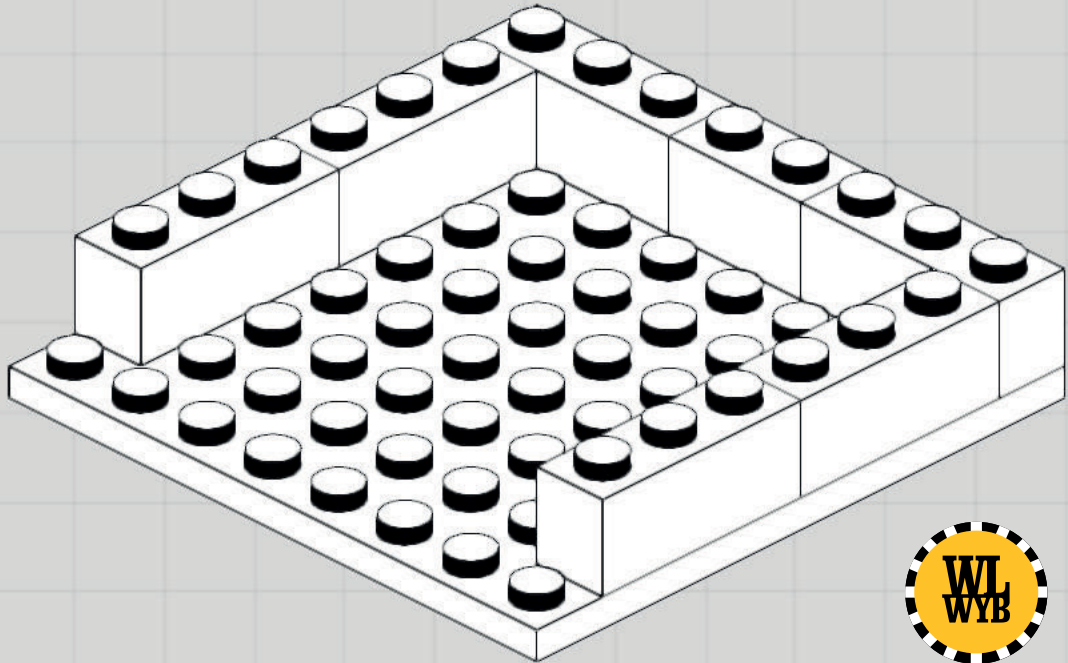

# 1

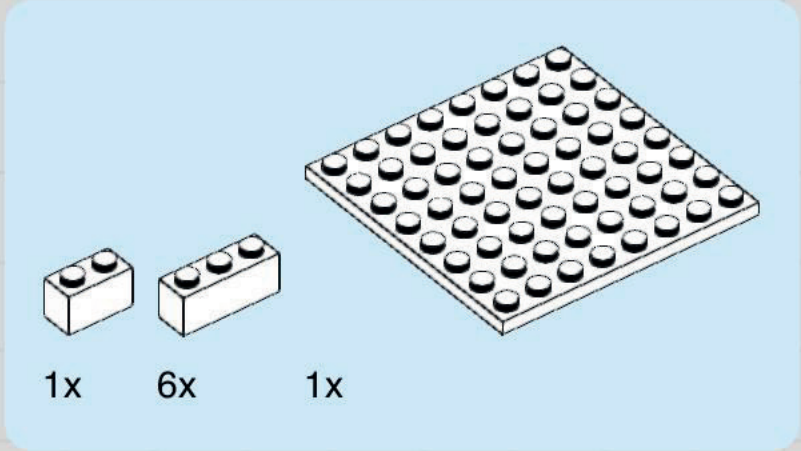

2



1x

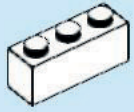

2x

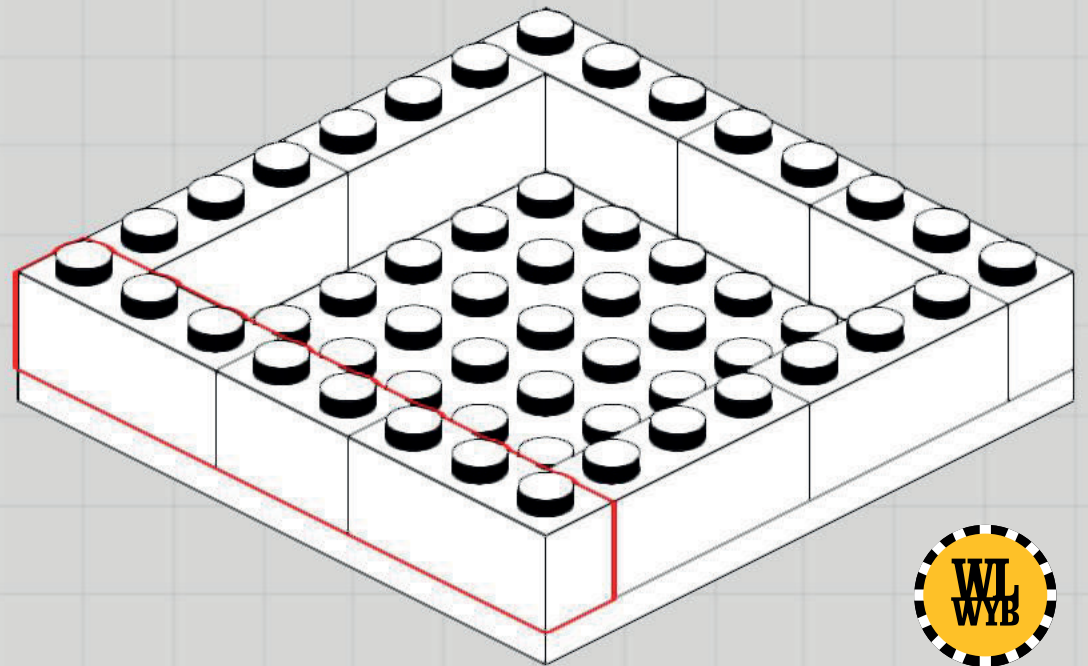

3



2x

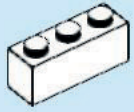

6x

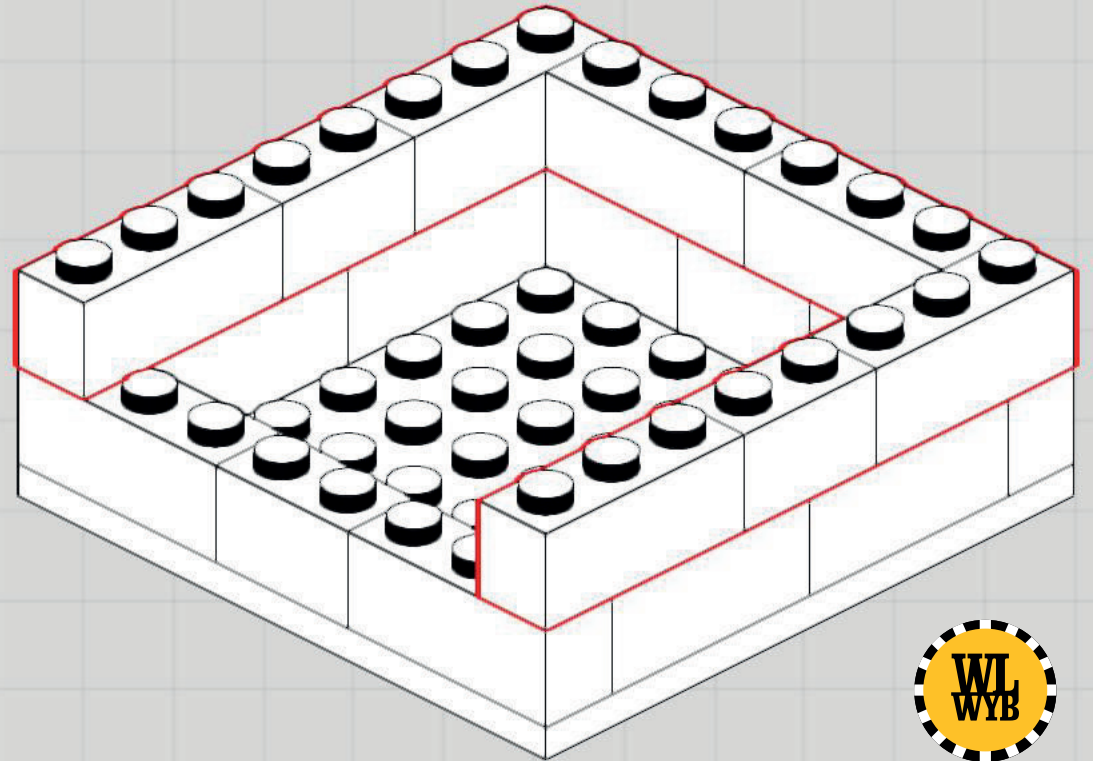

4



2x



2x

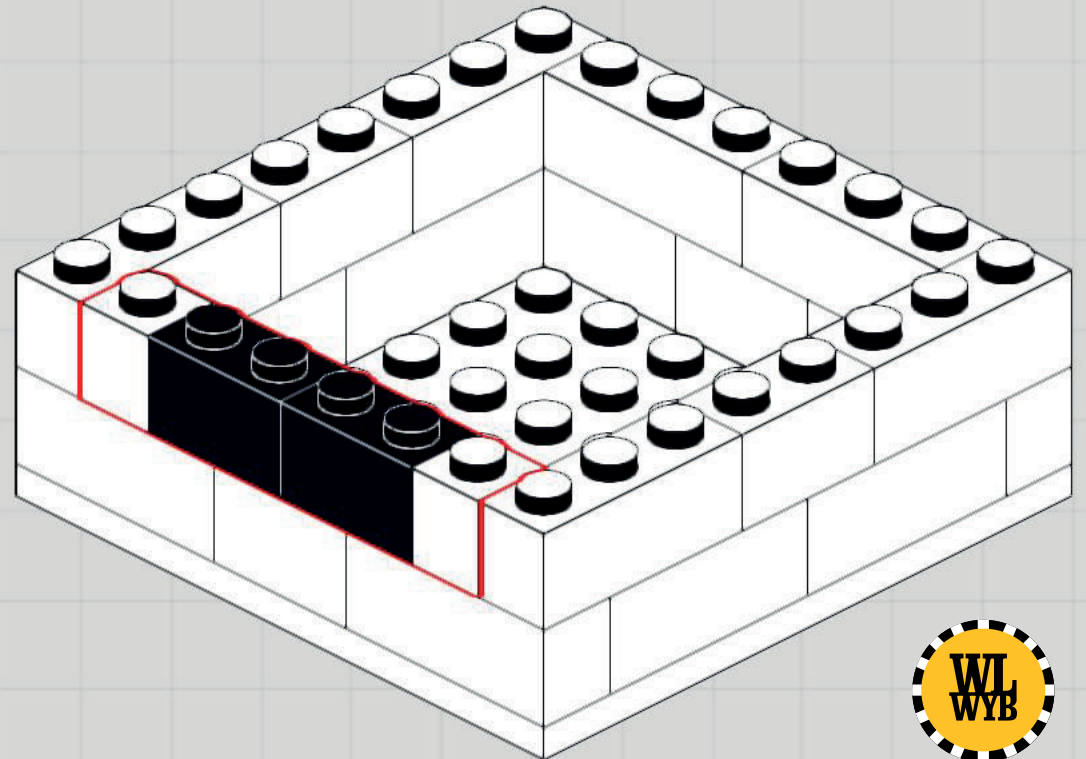

# 5



1x

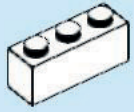

6x



Life Instruction:  
lawyer up, delete facebook,  
hit the gym.

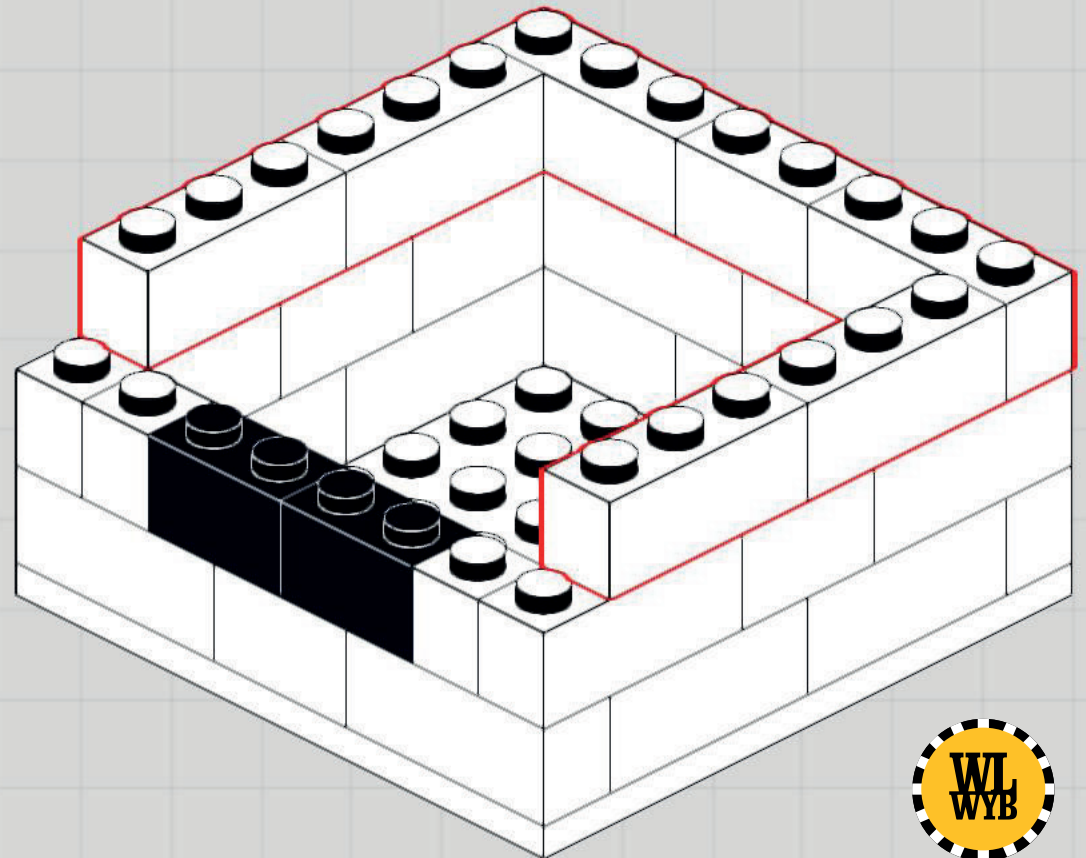



6

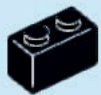

2x

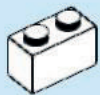

2x

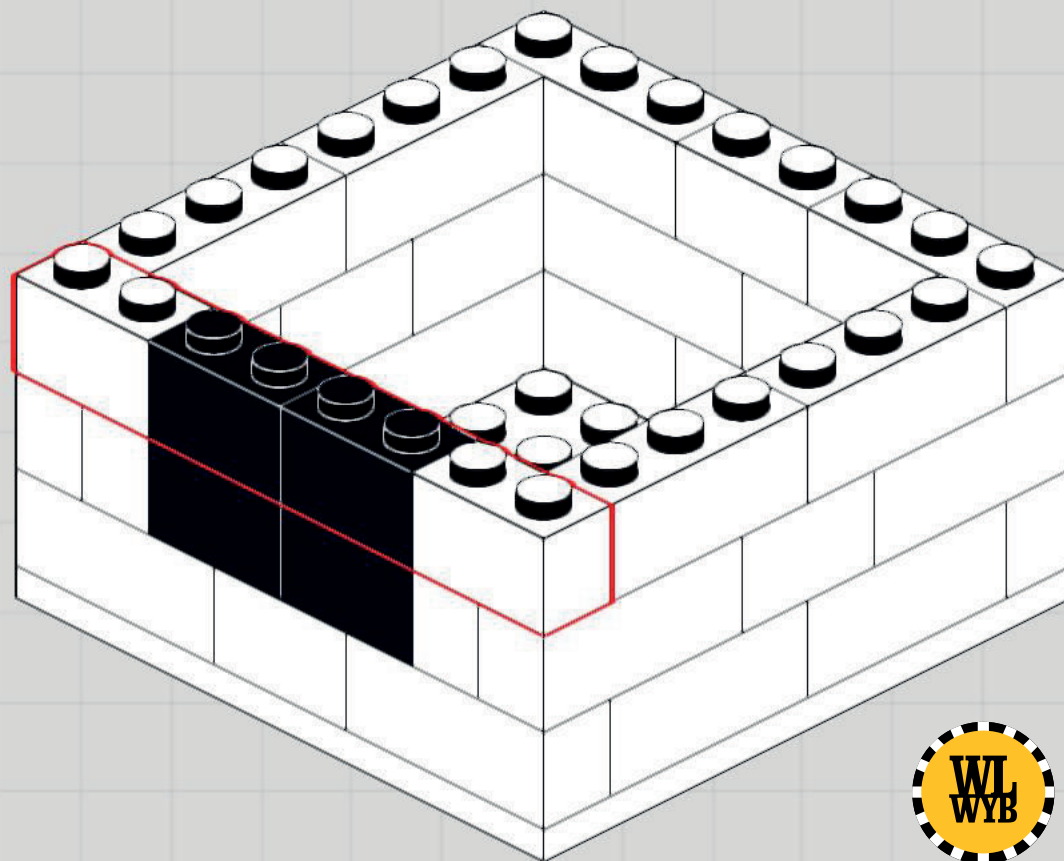

7



2x

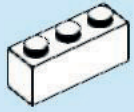

6x

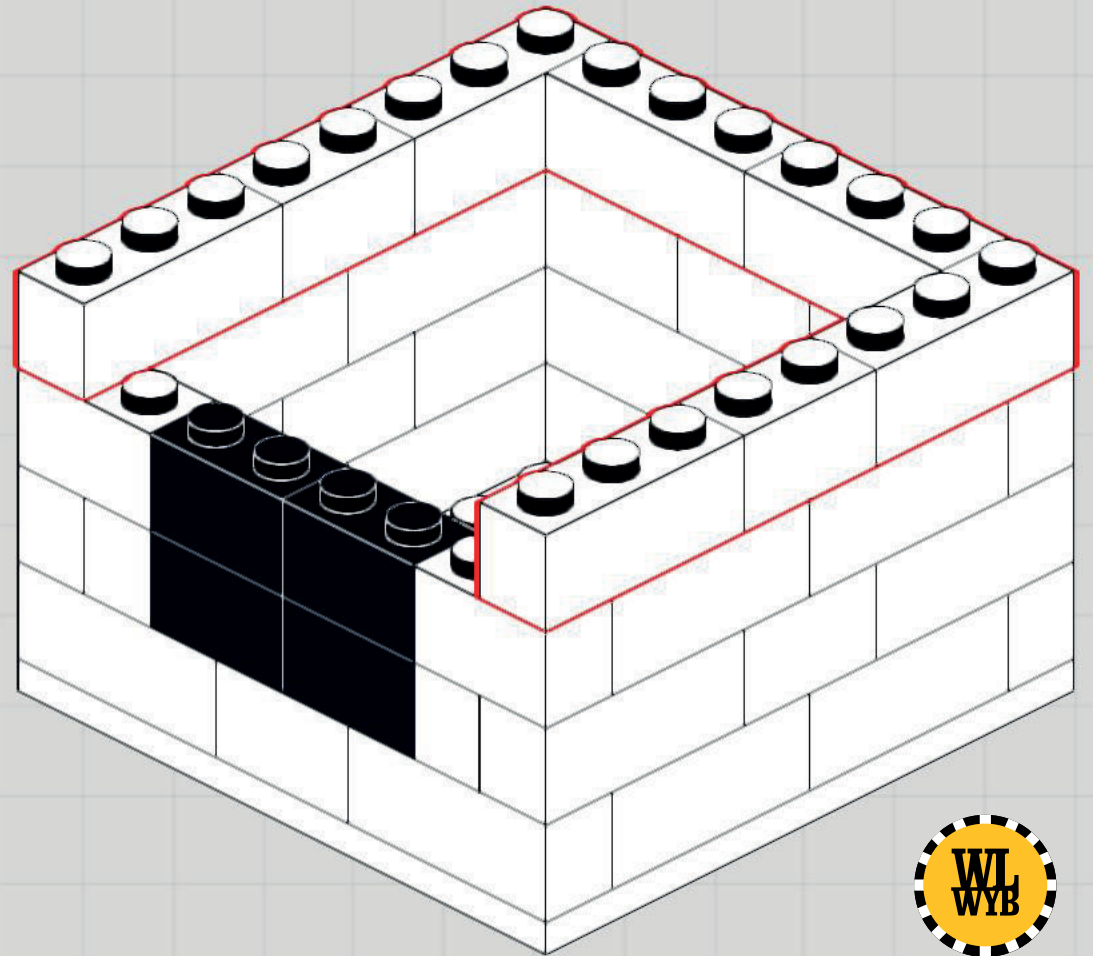



8

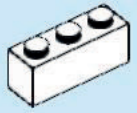

2x

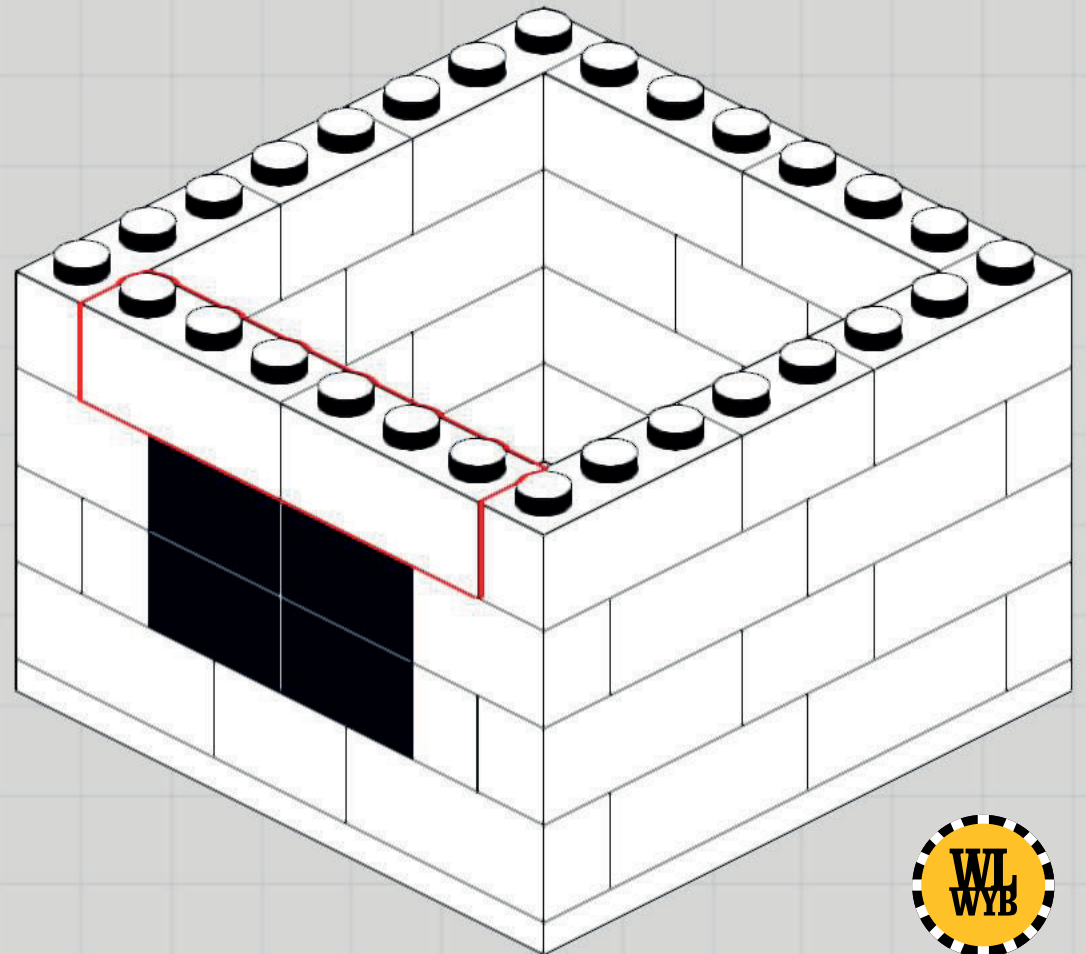

9



1x

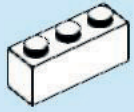

6x

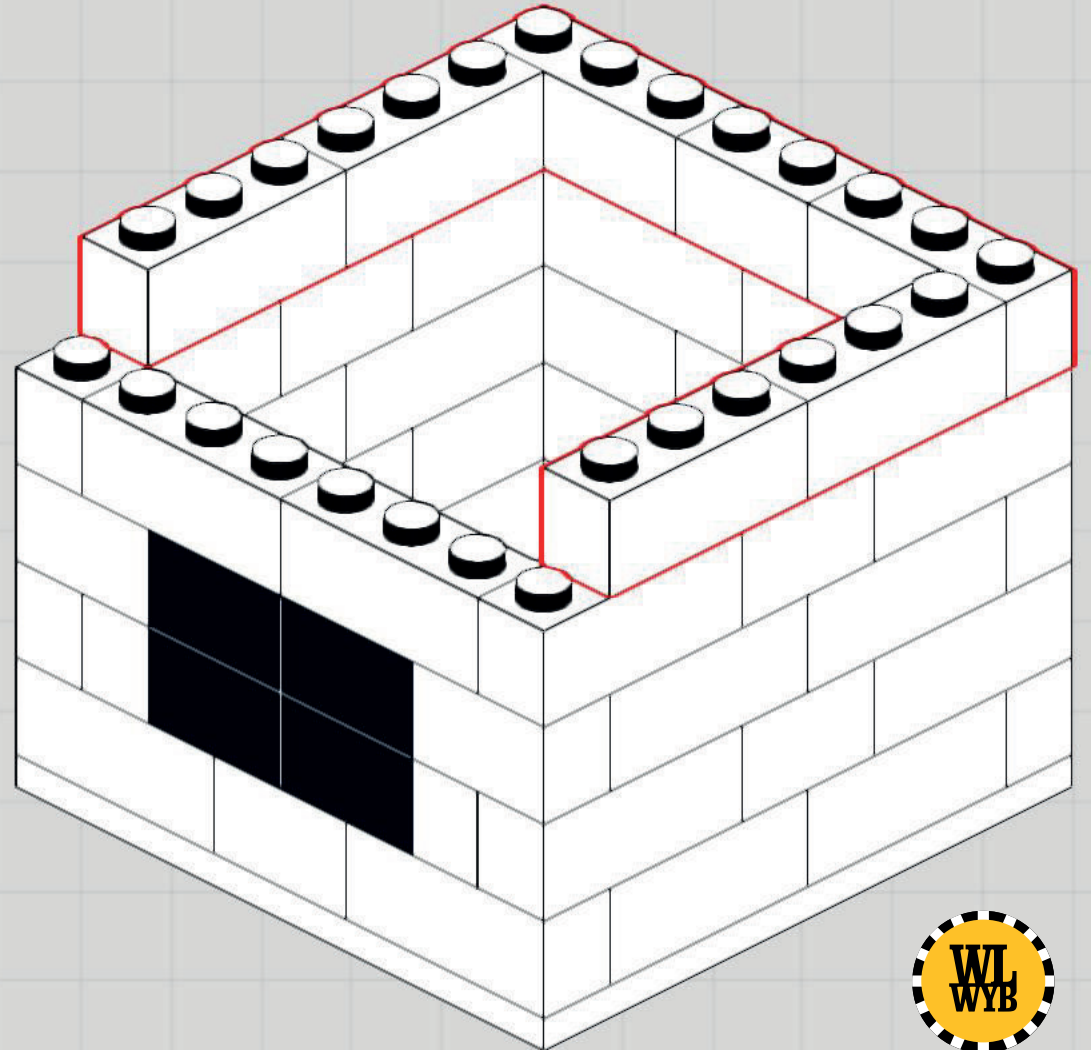

# 10

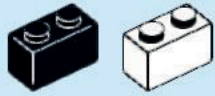

2x

2x



Pro Tip: Replace a white  
1x2 brick to another  
white 1x2 brick.  
Bet you don't dare!

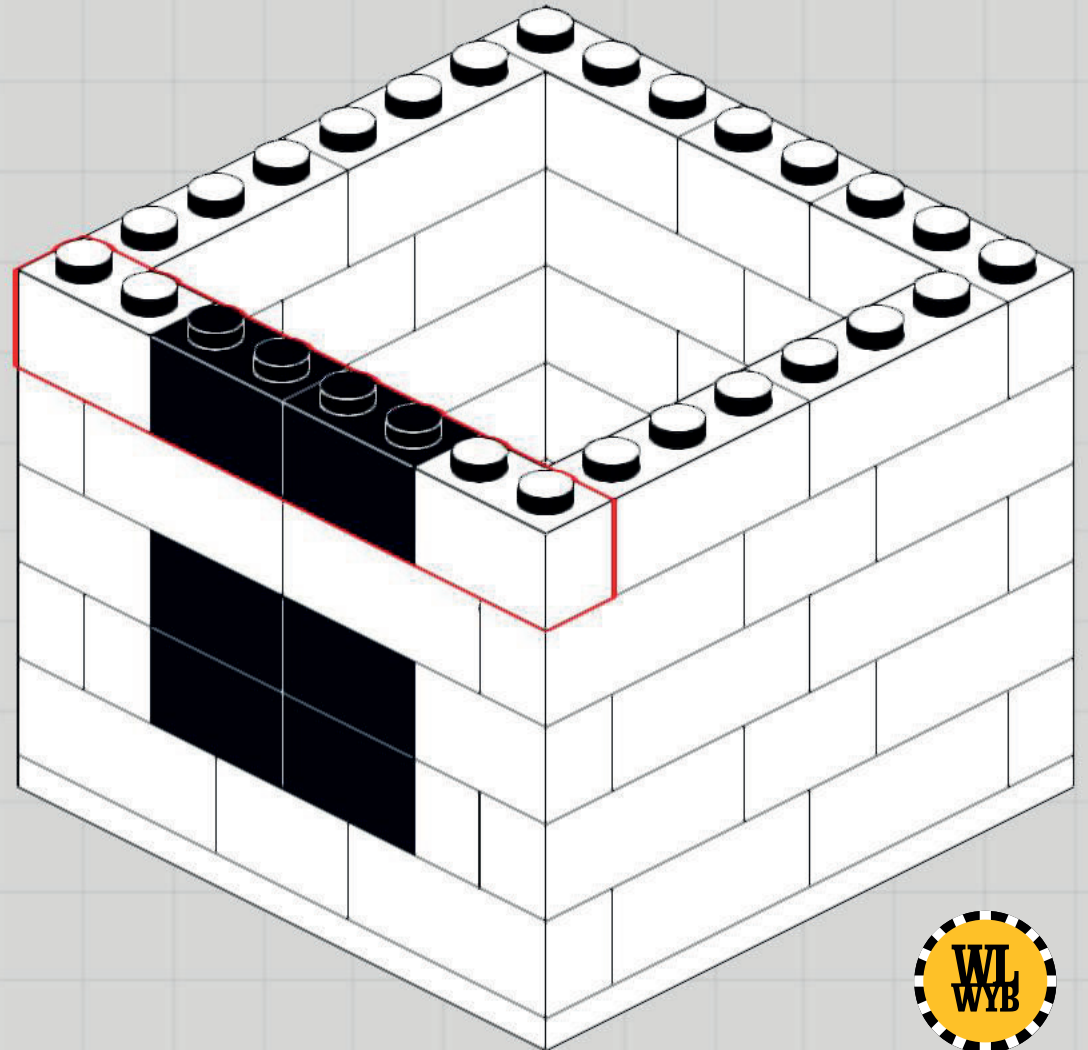

# 11

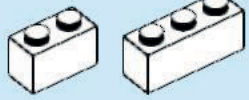

2x

6x

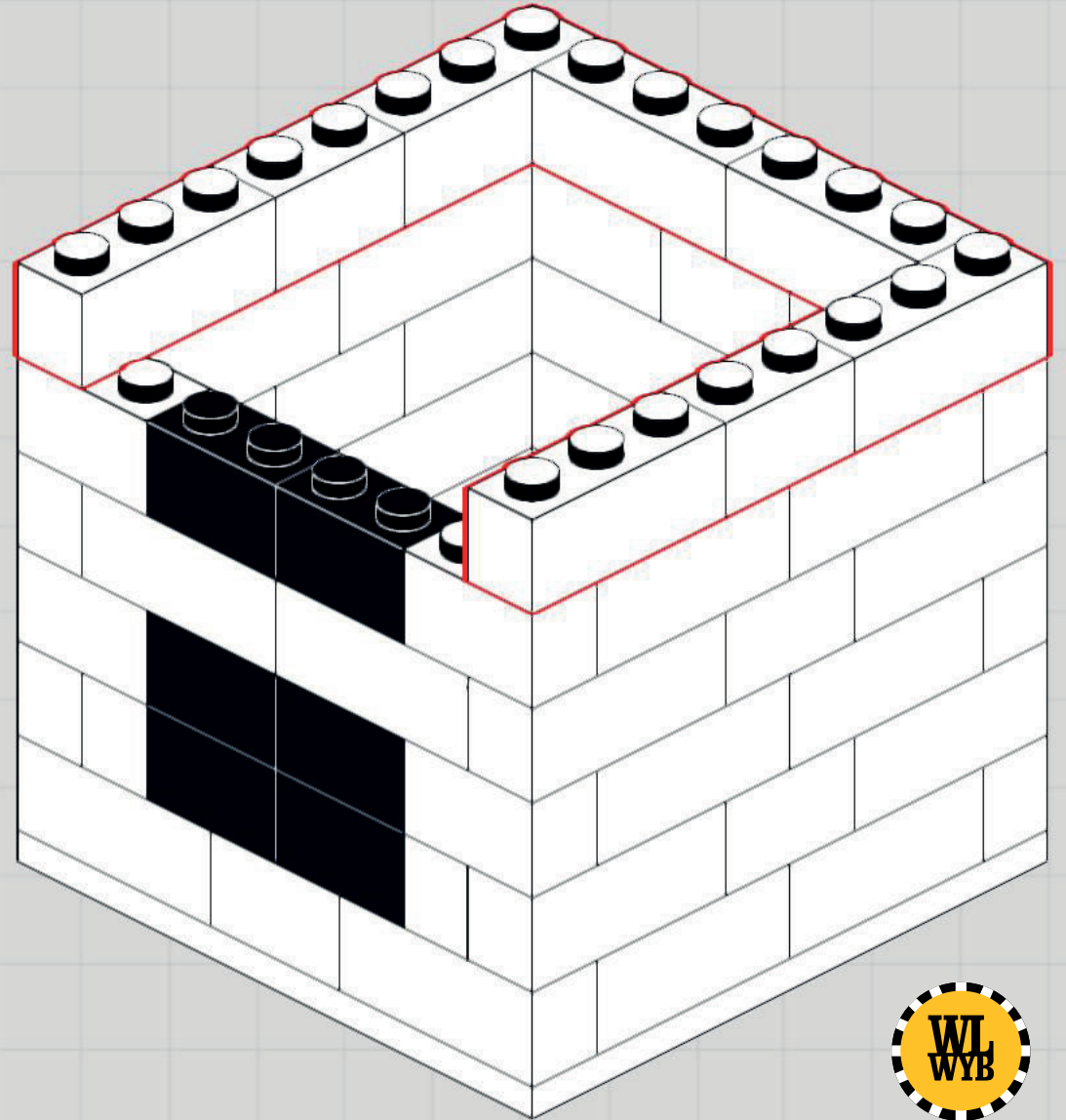

# 12



2x

2x

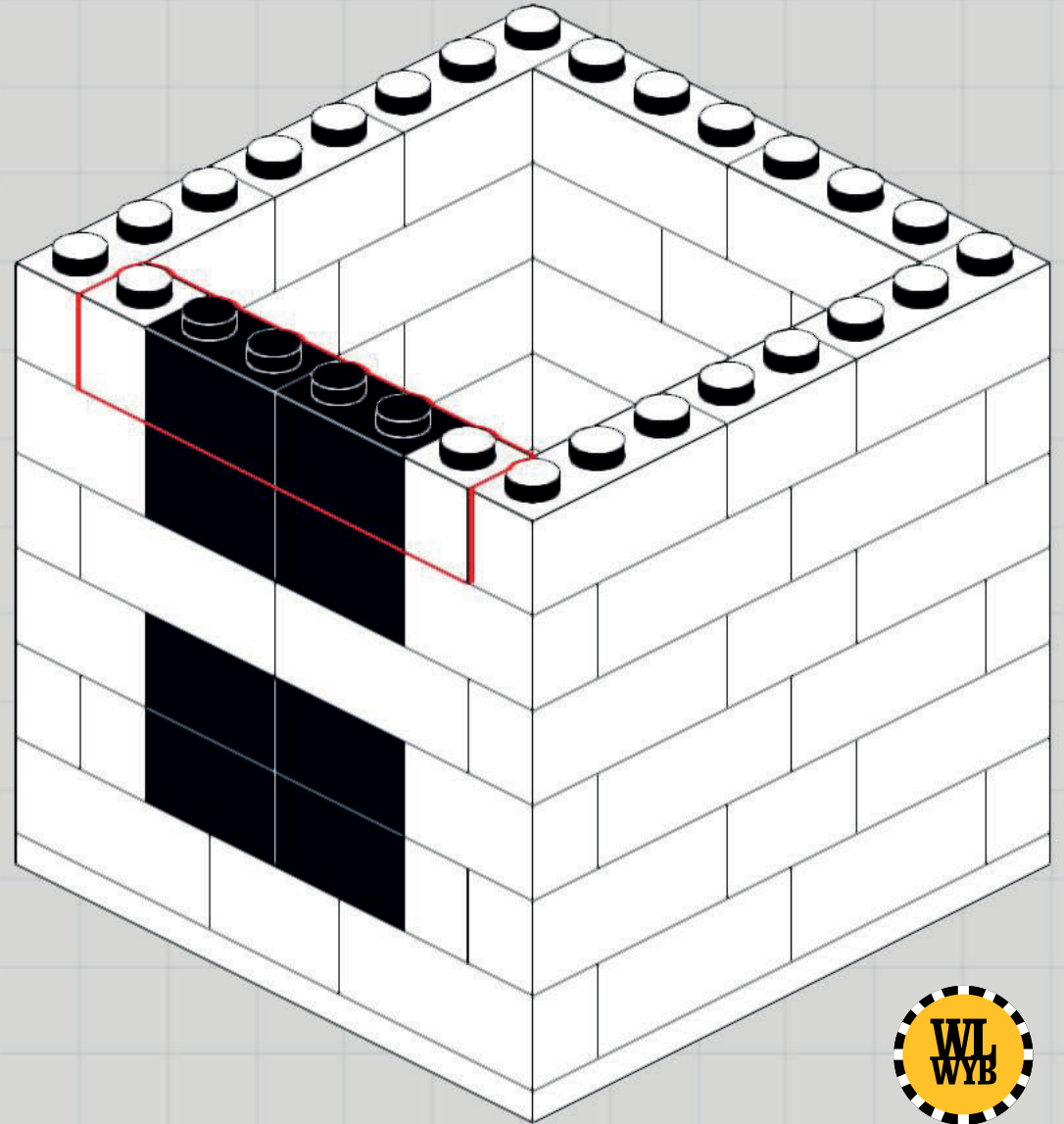



# 13

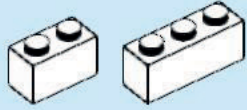

1x

6x

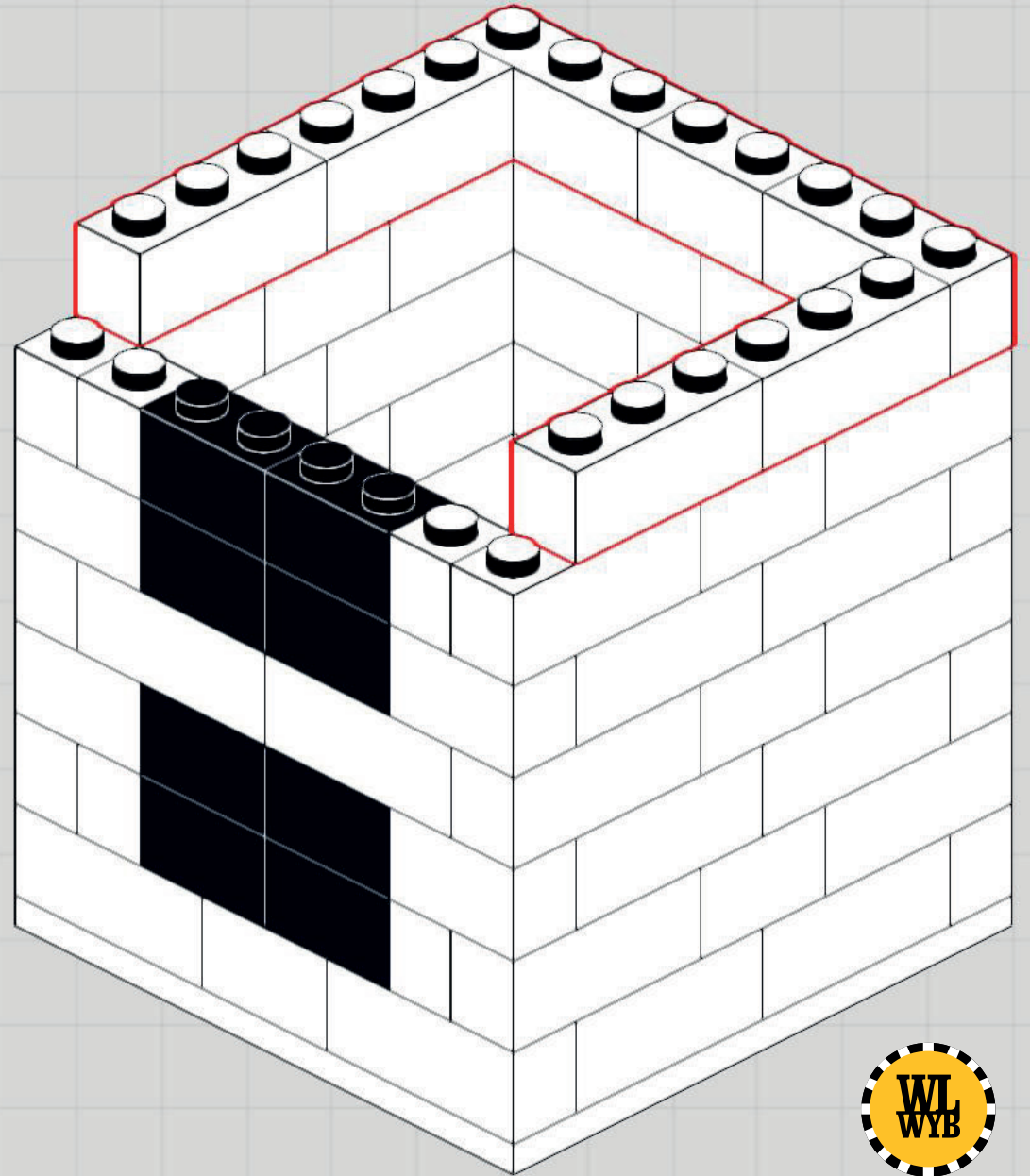



# 14

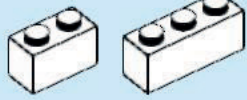

1x

2x

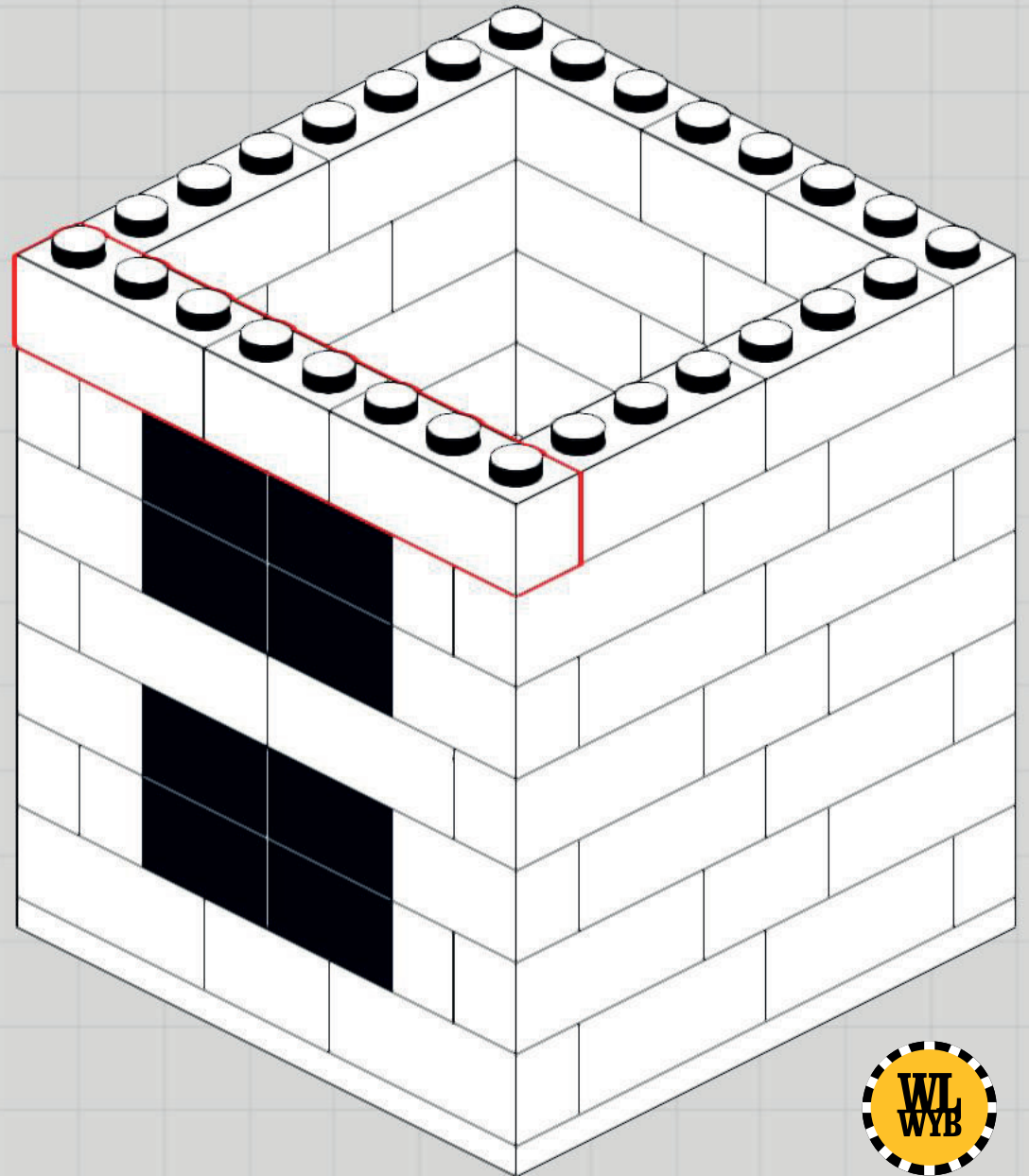

# 15

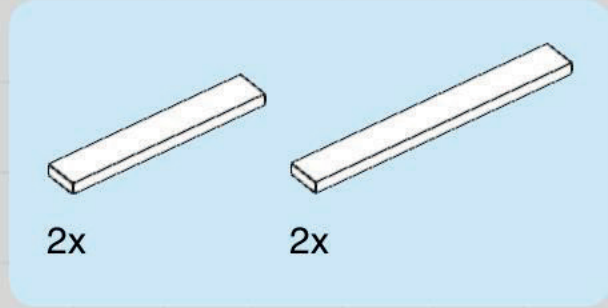

Now might be a good time to refresh your drink.

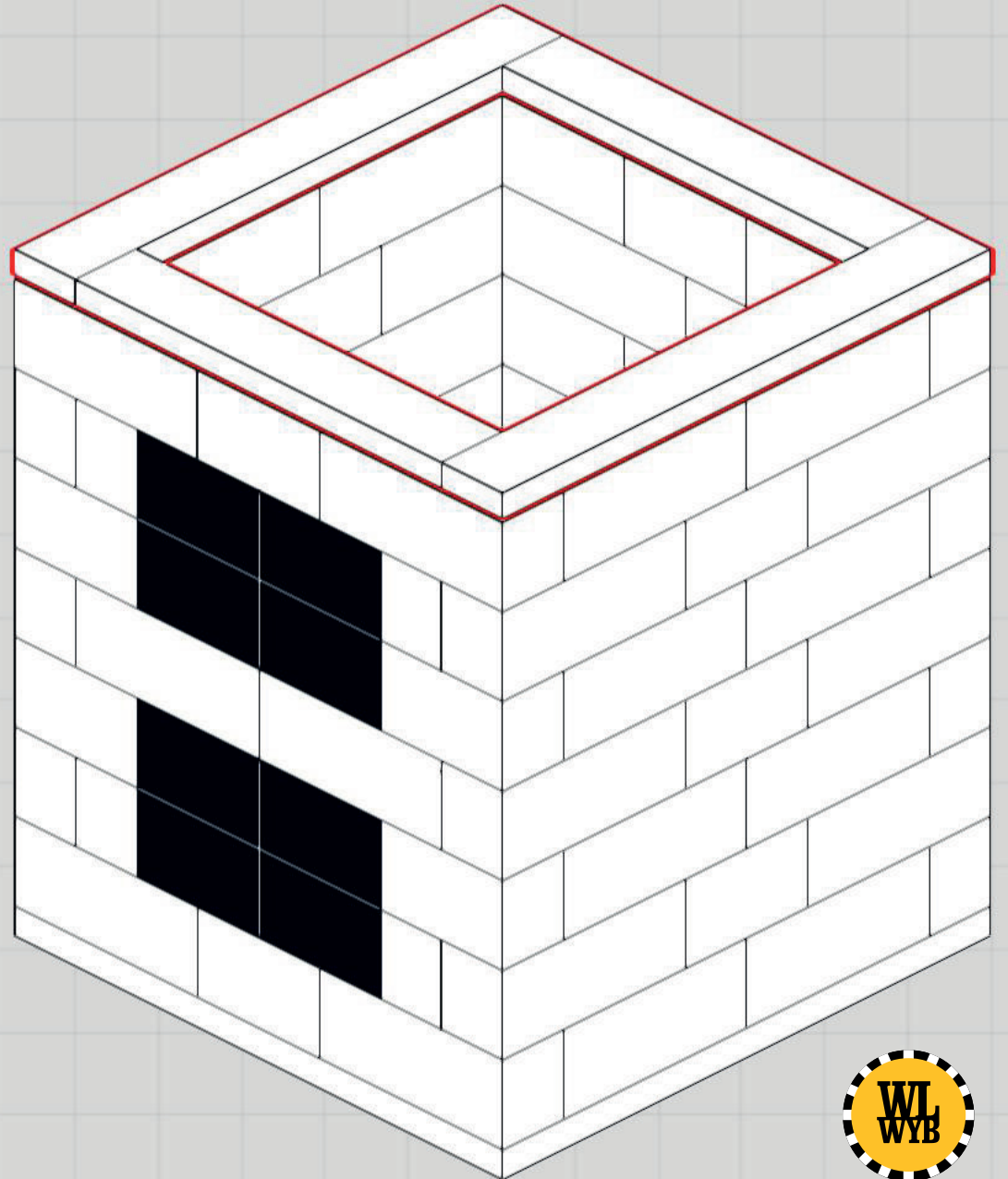

# **IMPORTANT:**

**Do not bleach or iron.**

**Do not bend, fold, spindle or mutilate.**

**Do not show your weakness.**

**Do not lock your keys in the car.**

**Do not wear white socks with black shoes.**

**DIGIT CUBE**

[www.wlwyb.com](http://www.wlwyb.com)

